



Ceva Extending Dining Table

CF_ACTH24443/OAK_bundle
CF_ACTH24444/SMK-OAK_bundle

PRODUCT PARTS INCLUDED

1

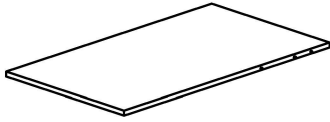

Top Plate x1

2

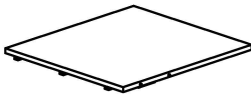

Extension Plate x1

3



Rail Side 1 x1

4



Rail Side 2 x1

5

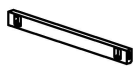

End Rail 1 x1

6



End Rail 2 x1

STEP 1



Ax16

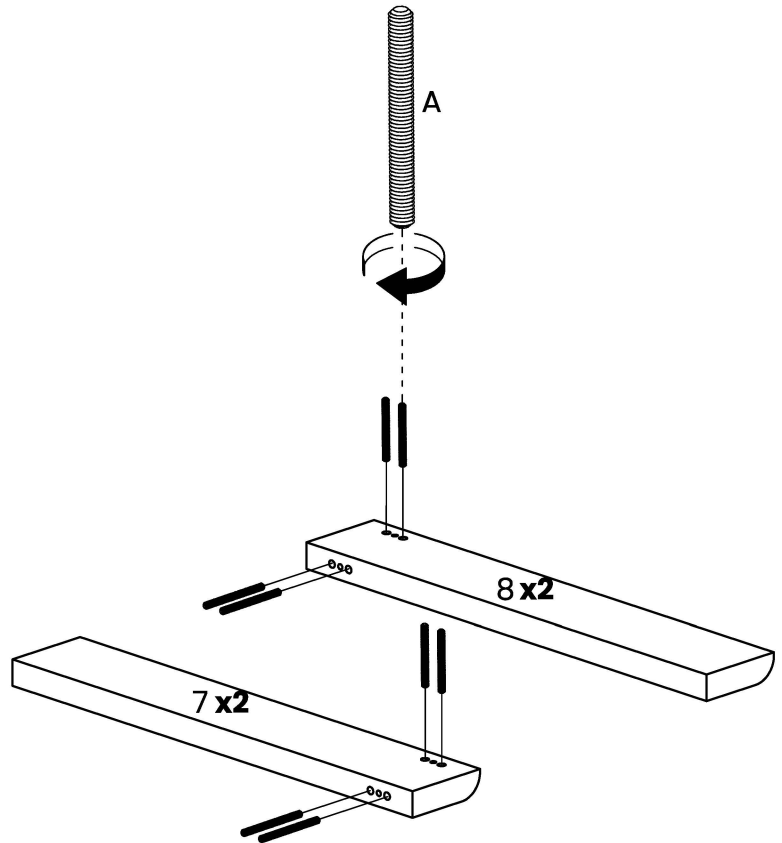

STEP 2



Fx4

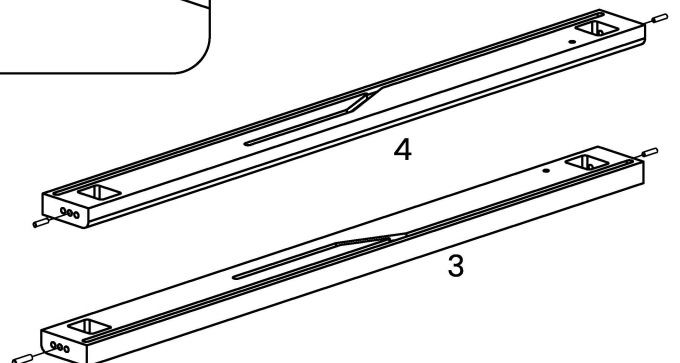
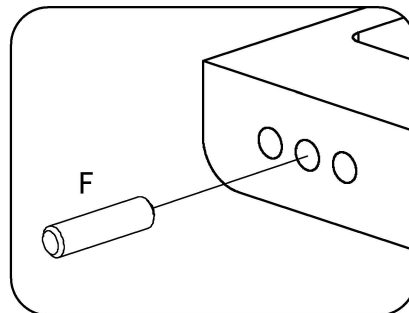

Ceva Extending Dining Table

CF_ACTH24443/OAK_bundle
CF_ACTH24444/SMK-OAK_bundle

PRODUCT PARTS INCLUDED

7



Leg 1 x2

8



Leg 2 x2

Ax16

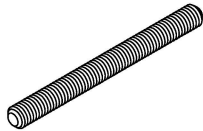

M8x90 mm

Bx16

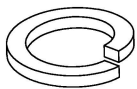

Ø8 mm

Cx16

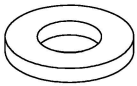

Ø8/Ø16 mm

Dx16

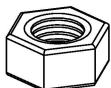

M8x12 mm

Ex1

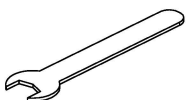

12 mm

STEP 3

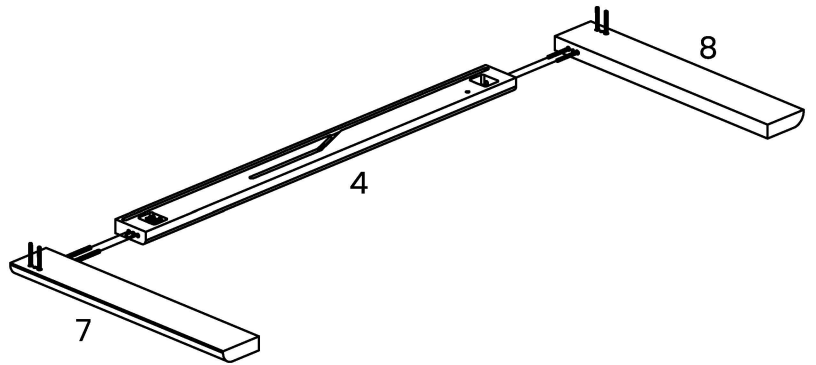
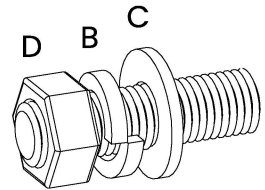
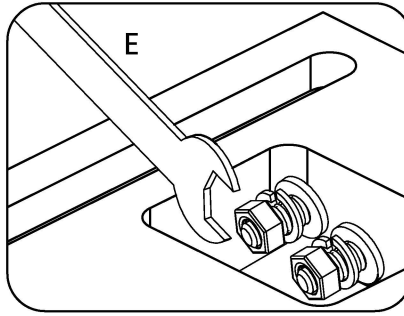
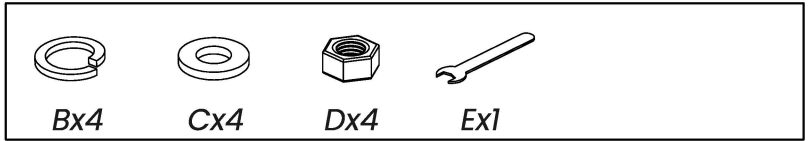

STEP 4

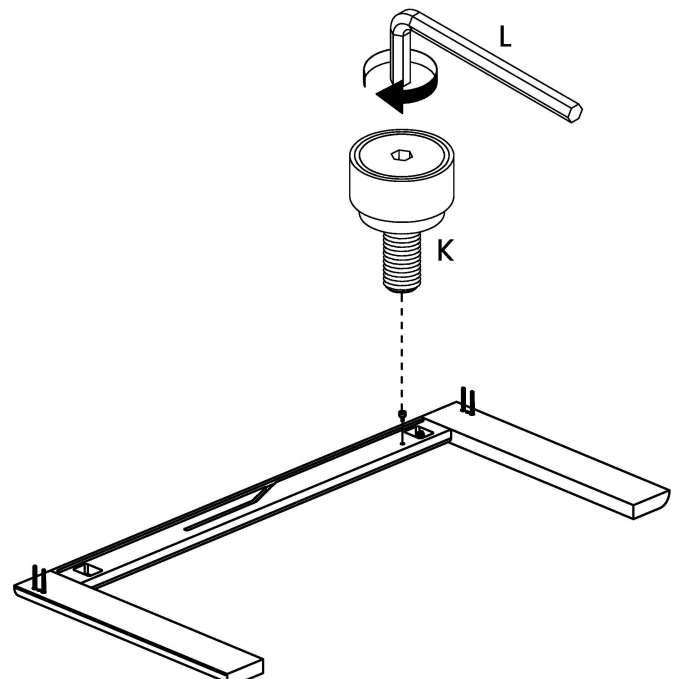
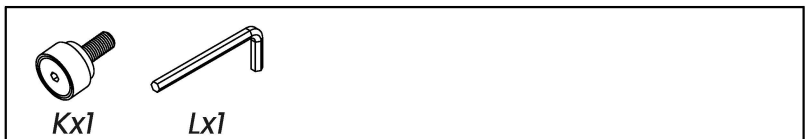



Ceva Extending Dining Table

CF_ACTH24443/OAK_bundle
CF_ACTH24444/SMK-OAK_bundle

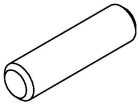
PRODUCT PARTS INCLUDED

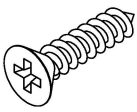
Fx8  $\text{Ø}10 \times 40 \text{ mm}$

Gx4  $\text{Ø}3,5 \times 16 \text{ mm}$

Hx4  $100 \times 30 \times 3 \text{ mm}$

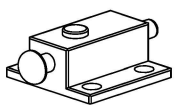
Jx1  $55 \times 36 \times 18 \text{ mm}$

Kx2  $\text{Ø}11 \times 17 \text{ mm}$

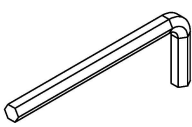
Lx1  $2,5 \text{ mm}$

STEP 5

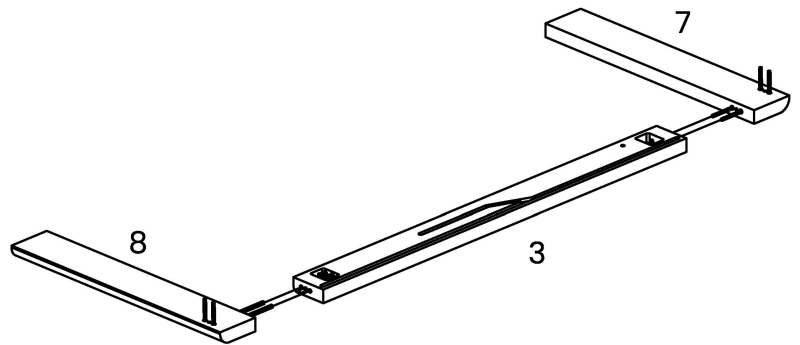
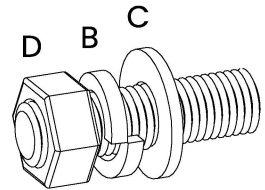
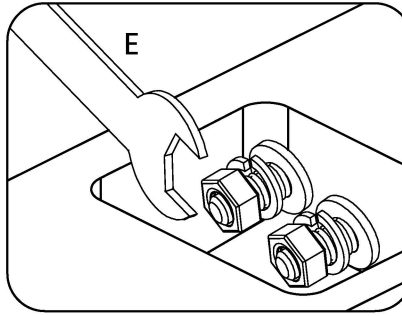
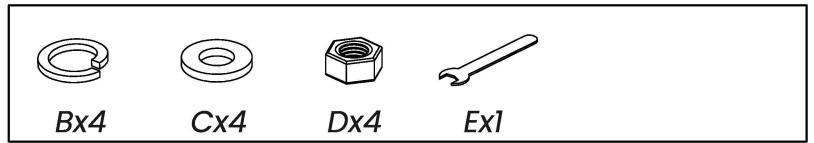

STEP 6

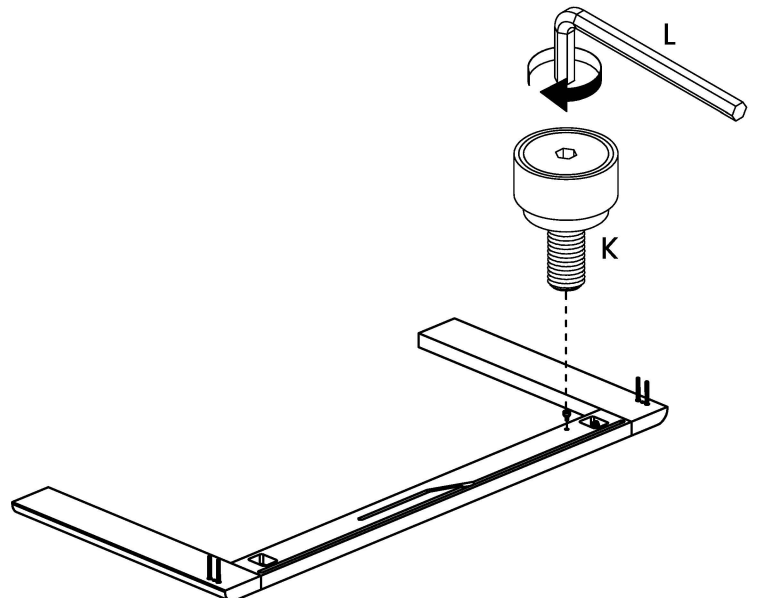
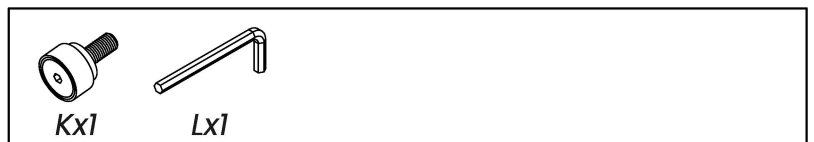

Ceva Extending Dining Table

CF_ACTH24443/OAK_bundle
CF_ACTH24444/SMK-OAK_bundle

STEP 7

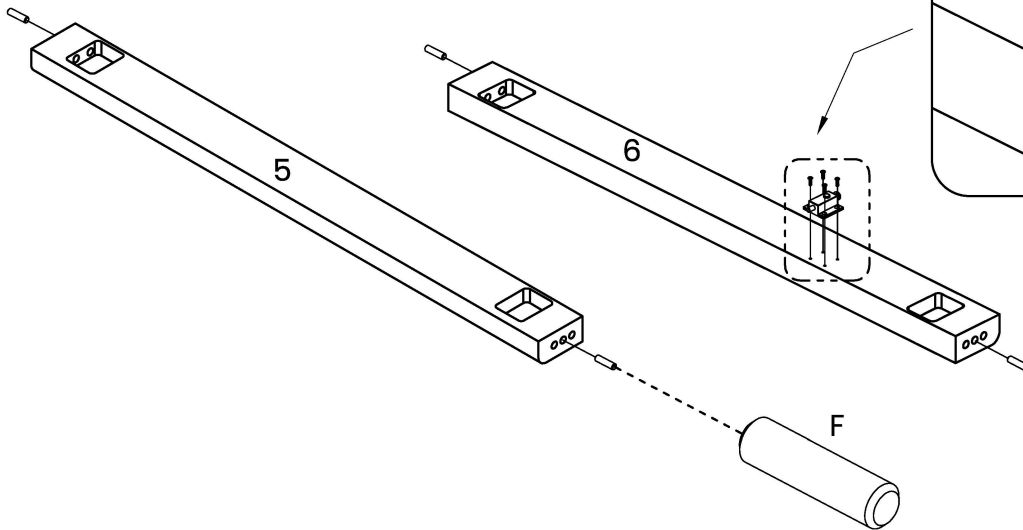
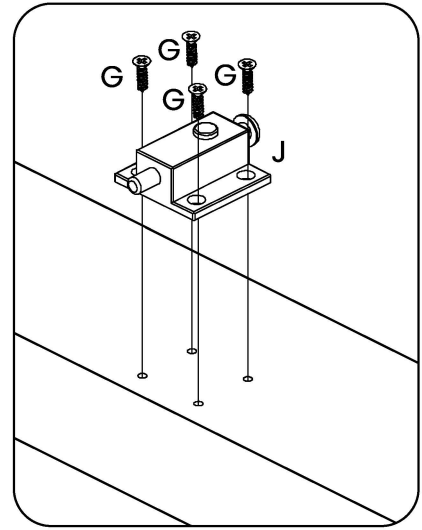
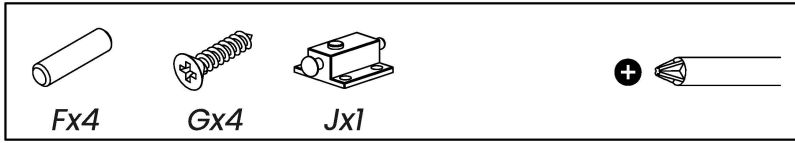

STEP 8

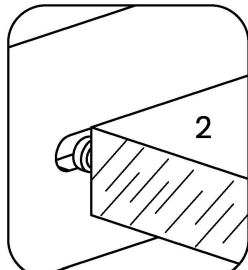
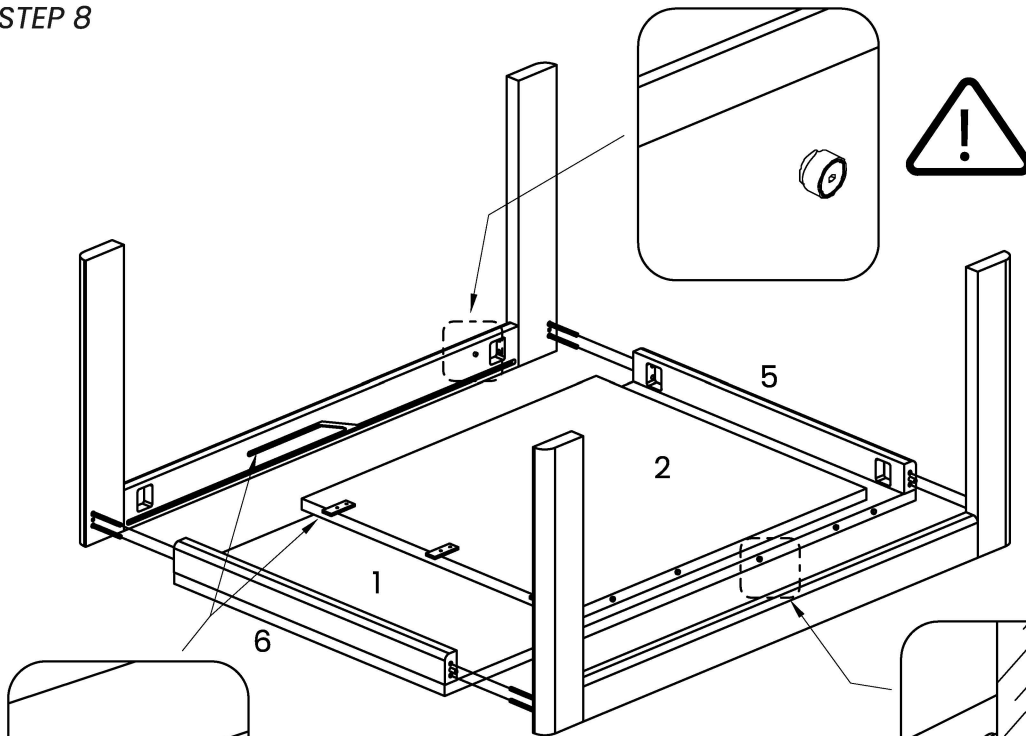

Be aware that the wheel in part 2 is placed in the top groove as shown.

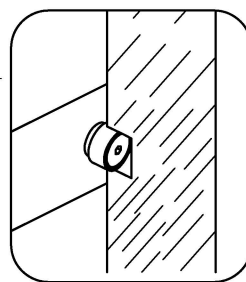

Be aware that the wheel in part 1 is placed in the bottom groove as shown.

C

Ceva Extending Dining Table

CF_ACTH24443/OAK_bundle

CF_ACTH24444/SMK-OAK_bundle

STEP 9

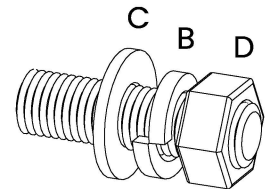
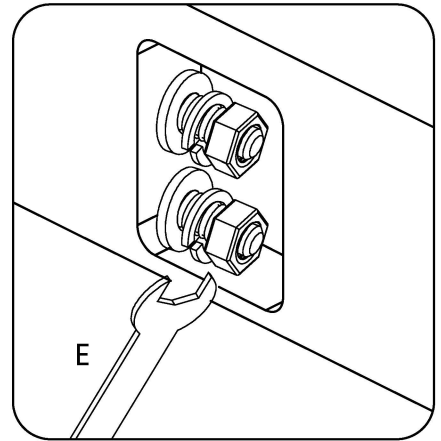
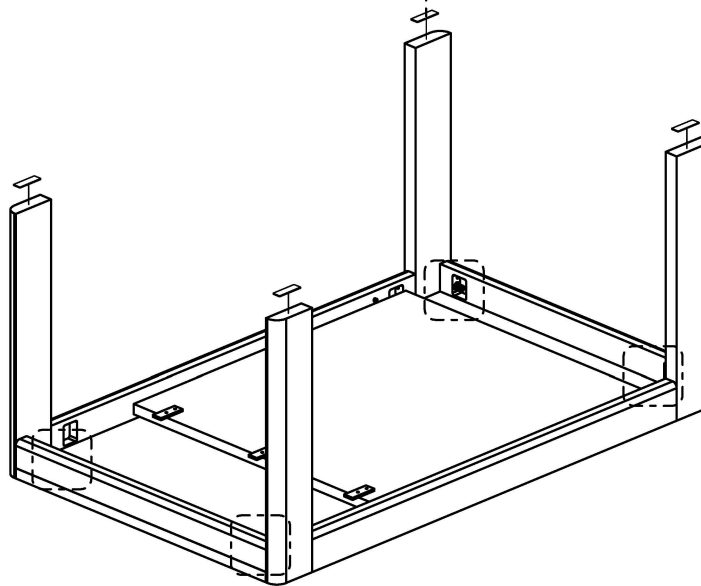
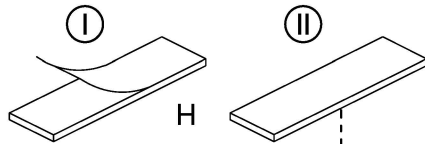
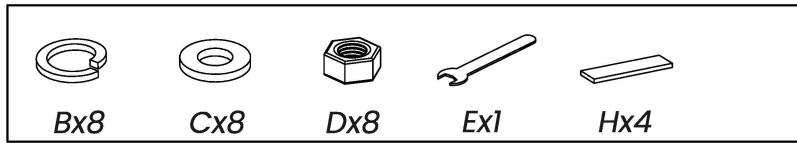

STEP 10

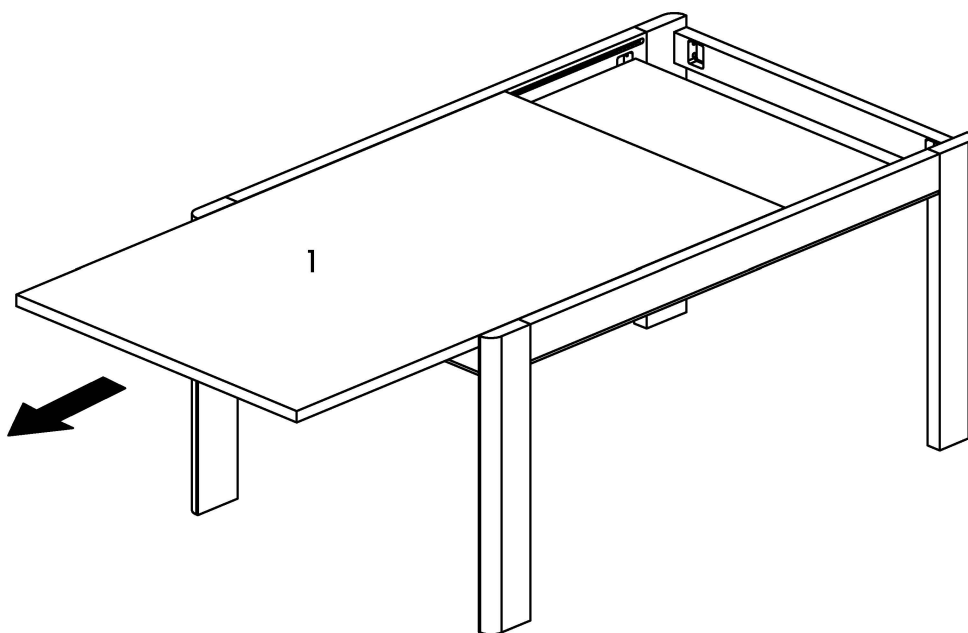

C

Ceva Extending Dining Table

CF_ACTH24443/OAK_bundle

CF_ACTH24444/SMK-OAK_bundle

STEP 11

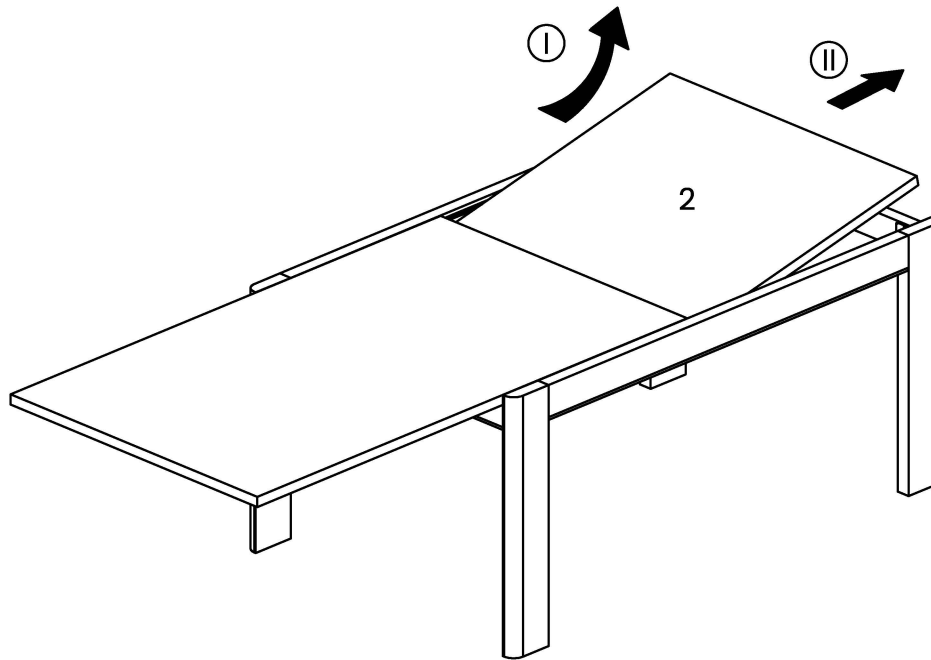

STEP 12

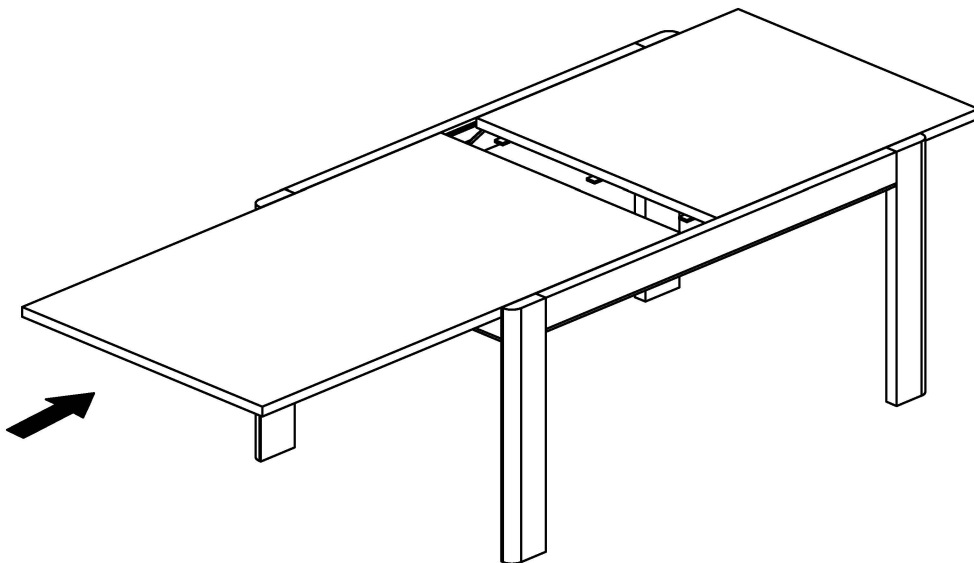

C

Ceva Extending Dining Table

CF_ACTH24443/OAK_bundle
CF_ACTH24444/SMK-OAK_bundle

STEP 13

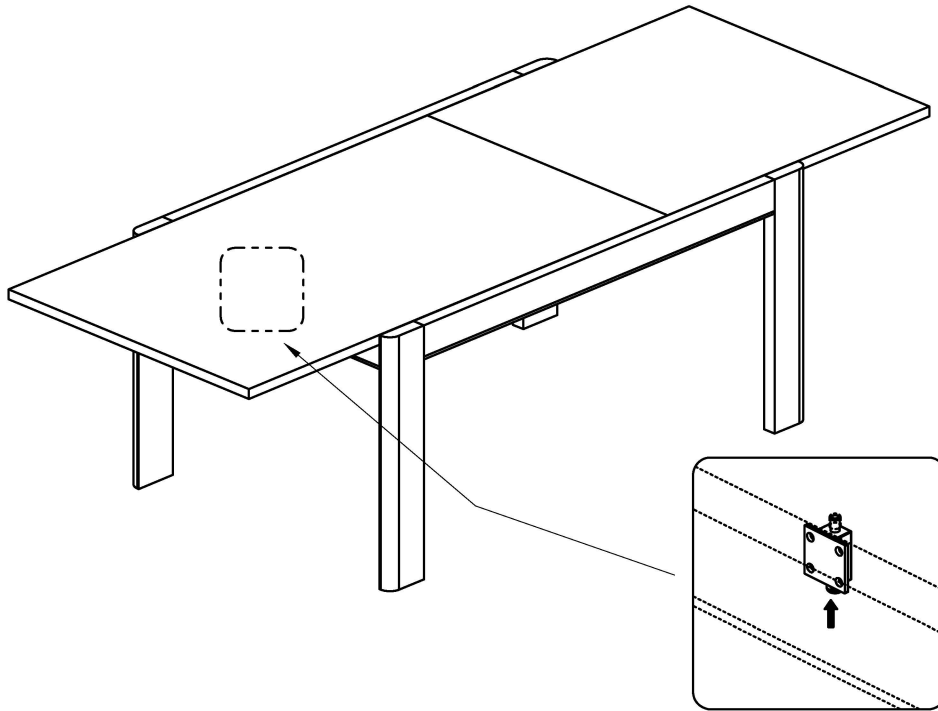

STEP 14

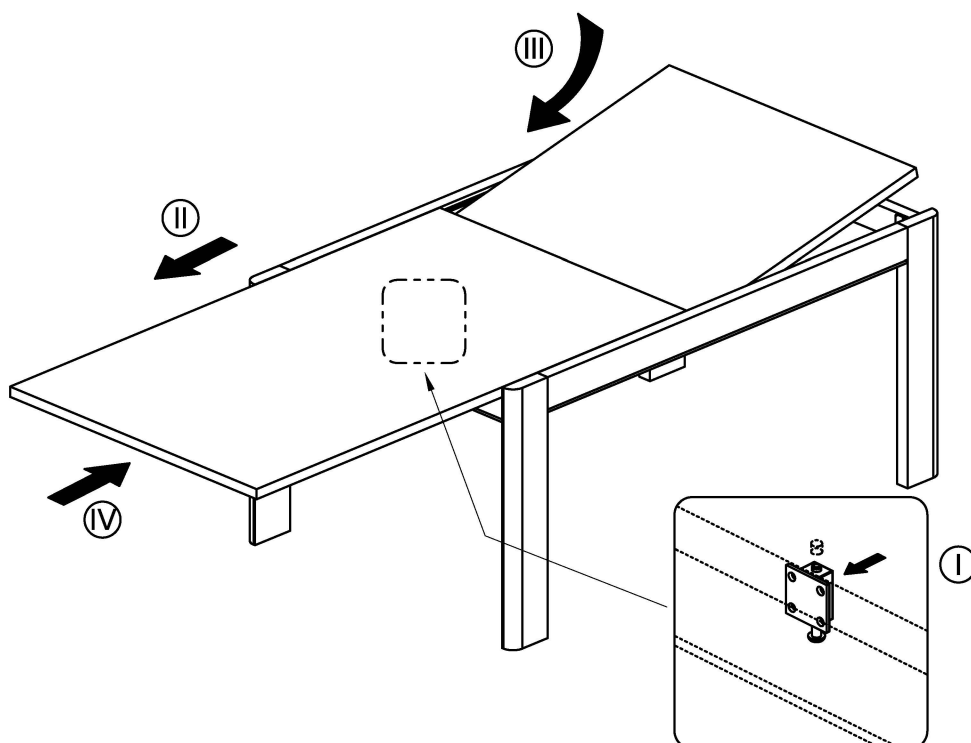

C

Ceva Extending Dining Table

CF_ACTH24443/OAK_bundle

CF_ACTH24444/SMK-OAK_bundle

STEP 15

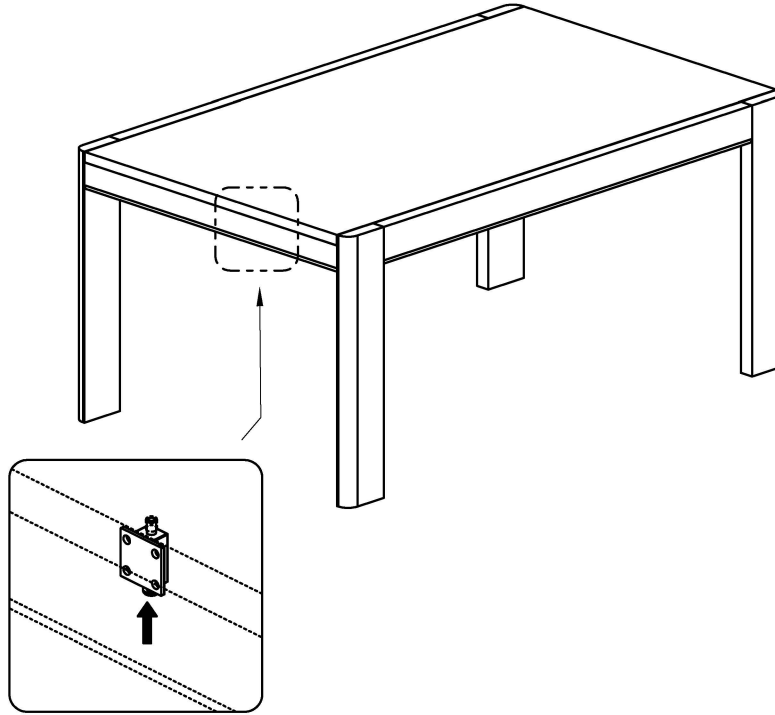

STEP 16

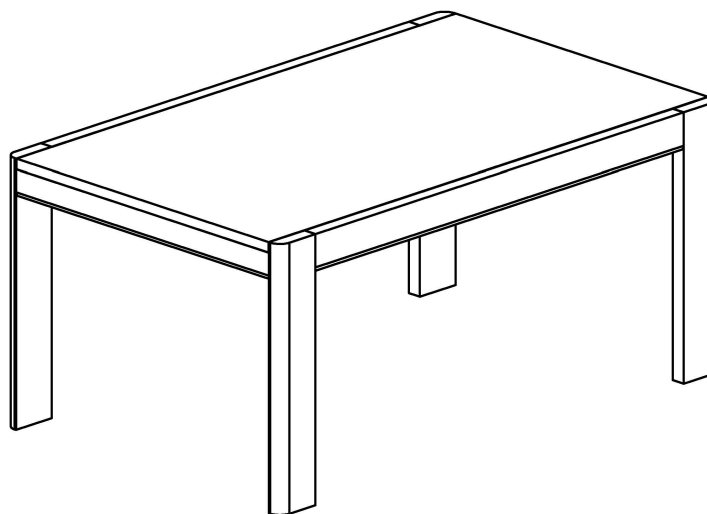

Assembled